

Robust series Battery Chargers

Technical handbook



11.Dec.2015

Table of Contents

1	Modes	3
1.1	Common features for all modes	4
2	Configurable items.....	5
2.1	Charging parameters	5
2.2	Parallel control.....	6
2.3	Series operation.....	6
2.4	IdcLimit	6
2.5	UdcLimit.....	7
2.6	Remote input.....	7
2.7	Remote output	7
2.8	Buttons F1 and F2.....	7
2.9	CAN node-ID	7
3	Editing charging configuration	8
4	Algorithms.....	11
4.1	LK10-06 freely ventilated lead-acid	11
4.2	LK10-04 freely ventilated lead-acid, using ionic mixing	12
4.3	LK20-09 sealed gel lead-acid.....	13
4.4	LK10-05 freely ventilated lead-acid, with constant voltage maintenance charging	14
4.5	PP100 freely ventilated lead-acid, with constant voltage maintenance charging	15
4.6	PP101 sealed gel lead-acid, with constant voltage maintenance charging.....	16
4.7	PP102 sealed gel lead-acid "Sonnenschein"	17
5	CAN remote control	18
5.1	Node-ID	18
5.2	Bit rate	19
5.3	Setting mode via CAN	19
5.4	SW version	20
5.5	Charger mode	21
5.6	PDO power supply mode.....	22
5.7	SDO power supply mode	24
5.8	Powerfinn power supply mode	25
5.9	Unidirectional power supply mode	28
6	Connections	29
7	Options and accessories	31
7.1	Radio module	31
7.2	Option cable with all wires connected	31
7.3	Battery temperature sensor and voltage sense	32
7.4	CAN cable	32
8	Dimensions	33

Introduction

For hardware specification, see separate document "Specification".

For installation and operation instructions, see "Installation and user manual".

This document presents remaining features of Robust series chargers; configuration, CAN remote control, connections and options.

This document applies to software version 5 and later if not otherwise stated.

Information is subject to change without notice.

1 Modes

Charger has several operation modes; for example charger, SDO power supply and several remote controlled power supply modes.

Charger mode is standalone device, which controls battery charging process according to selected internal algorithm and other charging parameters.

PDO power supply mode is remote controlled power supply that provides setting and measurement messages. It is necessary to keep sending messages. If required CAN messages are not received, power output is switched off after some seconds. Note the involved SW control loop behaviour. Constant voltage type load, for example battery, is needed for output to be stable. SW loop has slow response to load changes. Thus, this mode might be better described as CAN controlled battery charger.

SDO power supply mode is standalone power supply with configurable nonvolatile voltage and current settings. In this mode, charger outputs power immediately after startup. Configuration items UdCLimit and IdCLimit are used. This mode uses fast HW control loop, which is stable for almost all loads.

Powerfinn power supply mode is remote controlled power supply that provides close compatibility to Powerfinn PAP3200/CAN product family. This mode uses fast HW control loop, which is stable for almost all loads. This feature is available in software version 7 or later.

Unidirectional power supply mode replaces PDO power supply mode in special software type 11613011. It is a simple remote controlled power supply that provides voltage and current settings and enables compatibility to some other brands of chargers. Note the involved SW control loop behaviour. Constant voltage type load, for example battery, is needed for output to be stable.

Some modes can be set using the front panel. All modes can be set using CAN bus and as factory setting. For setting modes using front panel, see chapter "Editing charging configuration" . For setting mode using CAN bus, see chapter "Setting mode via CAN".

1.1 Common features for all modes

Powerfinn Robust series chargers feature dynamic power limit. This means, maximum voltage and maximum current can be set at same time. One of them can be output at one time. Depending on load, output operates on voltage, current or power limit. Limits are either maximums of the model or smaller values set by a charging algorithm, remote control messages or configured limits.

STOP button switches output off both in charger and power supply modes. Pressing STOP again restores output.

Remote input can be configured to start/stop functionality. Power output is on, if remote input is active (closed contact).

2 Configurable items

Some settings can be configured using front panel and CAN commands. Almost all settings can be configured using optional radio module. All settings can be set at the factory.

configuring method	documented in
front panel	chapter "Editing charging configuration"
CAN bus	chapter "CAN remote control"
radio	Micropower Access Service Tool documentation
factory setting	ask from your supplier. Convenient if your order large quantities.

Operation modes are described in chapter "Modes". Other items are listed below.

2.1 Charging parameters

This group of settings includes algorithm, battery capacity, cellcount, cable resistance and base load. These items are applied only in charger mode. These settings can be set also using CAN bus. See chapter "CAN remote control".

Algorithm number

configurable via	front panel: yes	CAN: yes	radio: yes	factory setting: yes
------------------	------------------	----------	------------	----------------------

Default value: 1

Algorithm number is unique identifier of algorithms within Micropower Access and Powerfinn Robust series of chargers. See chapter "Algorithms" for available algorithms and numbers.

Battery capacity

configurable via	front panel: yes	CAN: yes	radio: yes	factory setting: yes
------------------	------------------	----------	------------	----------------------

Default value: 50, unit: Ah, range: 50 ... 2000

A list of predefined values between 50 and 800 is available using the front panel. See chapter "Editing charging configuration". While these are often sufficient, battery capacity can be set freely using other methods. Accurate capacity setting ensures optimal charging process.

Number of cells

configurable via	front panel: no	CAN: yes	radio: yes	factory setting: yes
------------------	-----------------	----------	------------	----------------------

Default value: (according to nominal voltage of the model), unit:-, range: 6 ... 50 (naturally meaningful maximum depends on nominal voltage of the model).

Number of cells can be configured to a lower value than the nominal. For example 12 V battery can be charged using nominally 24 V charger.

Base load

configurable via	front panel: no	CAN: yes	radio: yes	factory setting: yes
------------------	-----------------	----------	------------	----------------------

Default value: 0, unit: mA , range: 0 ... 65535

Eventual current consumption of a load parallel to battery during charging can be compensated with this parameter.

Cable resistance

configurable via	front panel: no	CAN: yes	radio: yes	factory setting: yes
------------------	-----------------	----------	------------	----------------------

Default value: 0, unit: mOhm, range: 0 ... 99

Voltage drop in cabling between charger and battery can be compensated with this parameter. Depending on algorithm, this can improve charging process efficiency. Be careful not to overcompensate as this can result in unstable operation and too high cell voltages.

2.2 Parallel control

configurable via	front panel: yes	CAN: no	radio: yes	factory setting: yes
------------------	------------------	---------	------------	----------------------

Default value: off, range: off/on

This setting enables group of chargers, connected in parallel, to deliver large current. When value "on" is selected, this charger controls other Robust series chargers over CAN bus. Other chargers in group should be configured with default values (charger mode, parallel control off).

Software version 6 or later is required for this feature.

This kind of parallel operation is possible in charger and PDO power supply modes.

In charger mode, the master charger (with parallel setting on) controls the other chargers. Up to five chargers can be connected. Eventual optional connections should be made to the master charger.

In PDO power supply mode, the master charger appears as one charger to CAN system controller.

2.3 Series operation

Series operation for large output voltage is not supported by Robust software. Connecting Robust chargers in series is not recommended.

2.4 IdcLimit

configurable via	front panel: no	CAN: yes	radio: yes	factory setting: yes
------------------	-----------------	----------	------------	----------------------

Default value: max. current of the model, unit: A, range: 0...max. current of the model

Parameter IdcLimit defines maximum DC current output. In case of other DC current limits, for example that calculated by charging algorithm or CAN messages in PDO power supply mode, lowest limit defines maximum current output. IdcLimit is not applied in Powerfinn power supply mode. IdcLimit is also the current setting in SDO power supply mode. See chapter "CAN remote control" - "SDO power supply mode" for CAN messages.

2.5 UdcLimit

configurable via	front panel: no	CAN: yes	radio: yes	factory setting: yes
------------------	-----------------	----------	------------	----------------------

Default value: nominal voltage of the model, unit: mV, range: 0...max. voltage of the model

UdcLimit is the voltage setting in SDO power supply mode.

See chapter "CAN remote control" - "SDO power supply mode" for CAN messages.

2.6 Remote input

configurable via	front panel: yes	CAN: no	radio: yes	factory setting: yes
------------------	------------------	---------	------------	----------------------

Default value: no function, range: no function, start/stop, stop

When value "start/stop" is configured, active remote input is required for power output.

Value "stop" is not documented yet.

This setting is valid in all modes.

Using front panel, values "no function" and "start/stop" can be selected.

Physical connection is documented in chapter "Connections".

2.7 Remote output

configurable via	front panel: no	CAN: no	radio: yes	factory setting: yes
------------------	-----------------	---------	------------	----------------------

Default value: "no function" in SW v6 and earlier, "mains" in SW v7 and later, range: no function, alarm, phase, BBC, water, air pump, mains

When value "alarm" is configured, remote output relay is activated during all alarms.

When value "mains" is configured, remote output relay is activated whenever charger is mains powered.

This setting is valid in all modes.

Physical connection is documented in chapter "Connections".

Remote output can be connected also to button F1 or F2. Button connection overrides other functions using the remote output.

Remote output has some additional configuration possibilities. For description of these, see MP Access documentation.

2.8 Buttons F1 and F2

configurable via	front panel: no	CAN: no	radio: yes	factory setting: yes
------------------	-----------------	---------	------------	----------------------

Default value: no function, range: no function, equalize, remote out

When value "equalize" is configured, the button will trigger equalize charging. This function tells the charging curve to run an equalize charge. How the actual equalize charge is performed is defined in the charging curve, normally when the battery is fully charged. The button can be pressed at any time even if no battery is connected.

When value "remote out" is configured, the button will toggle the remote output relay. Button connection overrides other functions using the remote output.

2.9 CAN node-ID

configurable via	front panel: no	CAN: yes	radio: yes	factory setting: yes
------------------	-----------------	----------	------------	----------------------

Default value: 1 in SW version 6 and earlier, 1Dh in SW version 7, range: 1 ... 127

This setting is applied in power supply modes. CAN node-IDs are automatically set in charger mode. See chapter "CAN remote control" for CAN messages.

3 Editing charging configuration





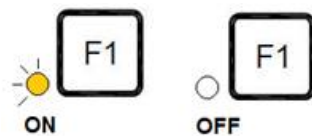

This chapter presents editing charging configuration using the front panel. Also CAN-bus and optional radio module can be used, see separate chapters.

1. Disconnect battery.
2. Connect mains power.
3. Wait until blue LED lits. Within 20 s, press STOP, and keep pressing for 10 s. LED's should flash shortly. Release STOP. Special configuration mode has been entered.
4. Press STOP to scroll down the list. List of items are in table below.
5. To set item on/off, press F1.



6. After you have selected algorithm and battery capacity (and eventual other selections), disconnect mains power. Configuration is automatically stored to non-volatile memory.

Following table applies to program version 2 and later. Bold text in coloured areas indicates LED “on”.

						item
1	red	yellow	green	blue	s.green	algorithm 1 LK10-06 freely ventilated lead-acid (default)
2	red	yellow		blue	s.green	algorithm 2 LK10-04 freely ventilated lead-acid
3	red		green	blue	s.green	algorithm 3 LK20-09 sealed gel lead-acid
4	red			blue	s.green	algorithm 16 LK10-05 freely ventilated lead-acid
5				blue	s.green	algorithm 17 PP100 freely ventilated lead-acid, with constant
6			green	blue	s.green	algorithm 18 PP101 sealed gel lead-acid
7		yellow		blue	s.green	algorithm 19 PP102 sealed gel lead-acid "Sonnenschein"
8		yellow	green	blue	s.green	algorithm --
9	red	yellow	green		s.green	capacity 50 Ah (default)
10	red	yellow			s.green	capacity 75 Ah
11	red		green		s.green	capacity 100 Ah
12	red				s.green	capacity 125 Ah
13					s.green	capacity 150 Ah
14			green		s.green	capacity 200 Ah
15		yellow			s.green	capacity 250 Ah
16		yellow	green		s.green	capacity 300 Ah
17	red	yellow	green	blue		capacity 350 Ah
18	red	yellow		blue		capacity 400 Ah
19	red		green	blue		capacity 450 Ah
20	red			blue		capacity 500 Ah
21				blue		capacity 550 Ah
22			green	blue		capacity 600 Ah
23		yellow		blue		capacity 700 Ah
24		yellow	green	blue		capacity 800 Ah
25	red	yellow	green			Charging mode
26	red	yellow				Remote input, off  -no function, on  -start/stop
27	red		green			CAN function
28	red					Parallel control
29						Battery monitoring unit control

Description of some configurable items

Charging mode and CAN function

Modes are set using two configurable items

mode	set item
Charger (default)	25, Charging mode: off 27, CAN function: off
PDO power supply	25, Charging mode: off 27, CAN function: on
SDO power supply	25, Charging mode: on 27, CAN function: on

Other modes are not accessible via front panel.

Remote input

Default value is "no function". When value "Start/Stop" is selected, active remote input is required for power output.

Battery monitoring unit control

Default setting is off. When optional radio module and battery monitoring unit are installed, charging process can be controlled by the battery monitoring unit. For more information, see Micropower Access documentation.

4 Algorithms

Verify compatibility of the algorithm with the battery manufacturer.

Notes

- "sealed" is a generic term for GEL and AGM types of lead-acid batteries, which are not freely ventilating to surrounding air.
- Current is indicated in terms of C, which is current compared to nominal capacity. For example 0.2 C for 100 Ah battery is 20 A.

4.1 LK10-06 freely ventilated lead-acid

Algorithm number: 1

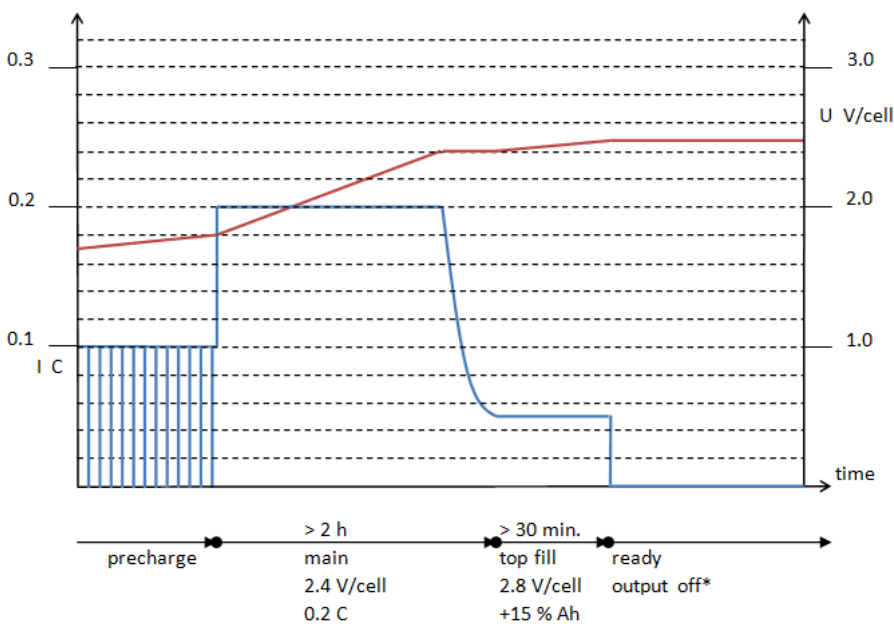

Charging phase "top fill" charges +15 % compared to charged Ah of main phase.

Battery temperature compensation:

- voltage -3 mV / °C per cell, neutral at 30 °C
- current derated to zero in the range [-30 ... -35] and [+45 ... +60] °C

* In maintenance phase, battery voltage is periodically checked. If it is below 2.17 V/cell, 2 minute 0.05 C current pulse is used.

4.2 LK10-04 freely ventilated lead-acid, using ionic mixing

Algorithm number: 2

Ionic mixing current pulses are used to reduce charging time without using air pump.

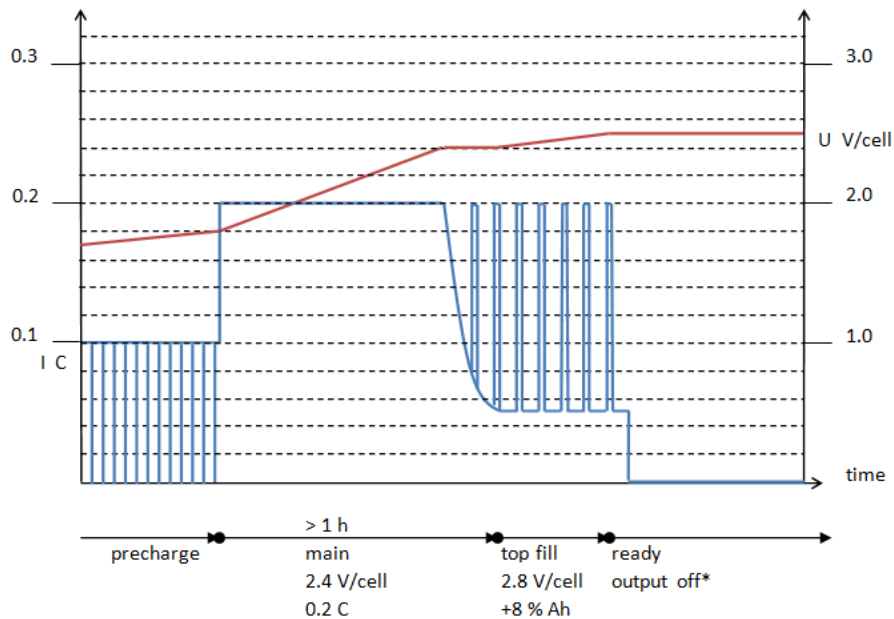

Charging phase "top fill" charges +8 % compared to charged Ah of main phase.

Battery temperature compensation:

- voltage -3 mV / °C per cell, neutral at 30 °C
- current derated to zero in the range [-30 ... -35] and [+45 ... +60] °C

* In maintenance phase, battery voltage is periodically checked. If it is below 2.17 V/cell, 2 minute 0.05 C current pulse is used.

4.3 LK20-09 sealed gel lead-acid

Algorithm number: 3

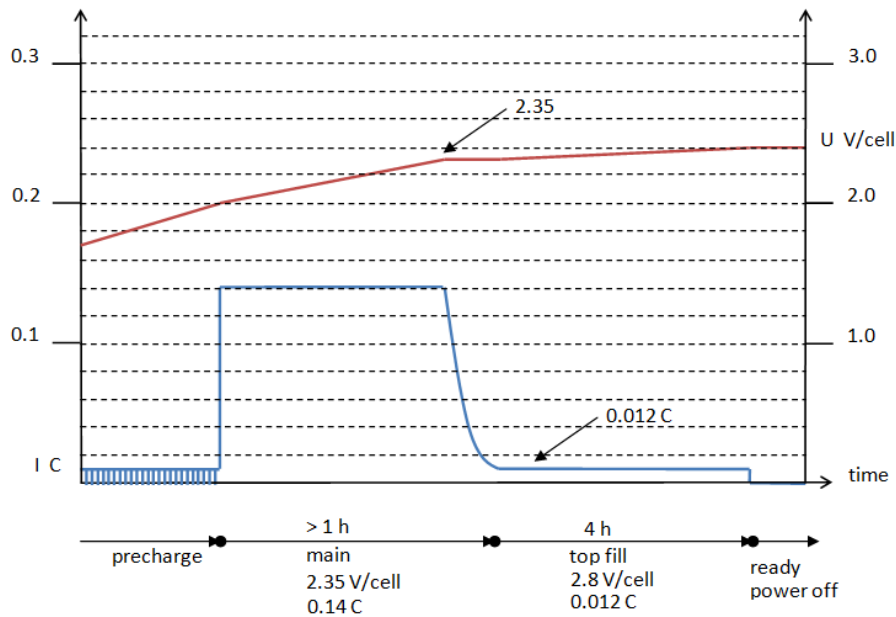

Battery temperature compensation: none.

This algorithm has equalization built-in. If battery is left connected to charger for 16 hours, a 30 h equalization phase runs with current 0.006 C and voltage 2.8 V/cell. This could be useful to perform equalizing over a weekend.

4.4 LK10-05 freely ventilated lead-acid, with constant voltage maintenance charging

Algorithm number: 16

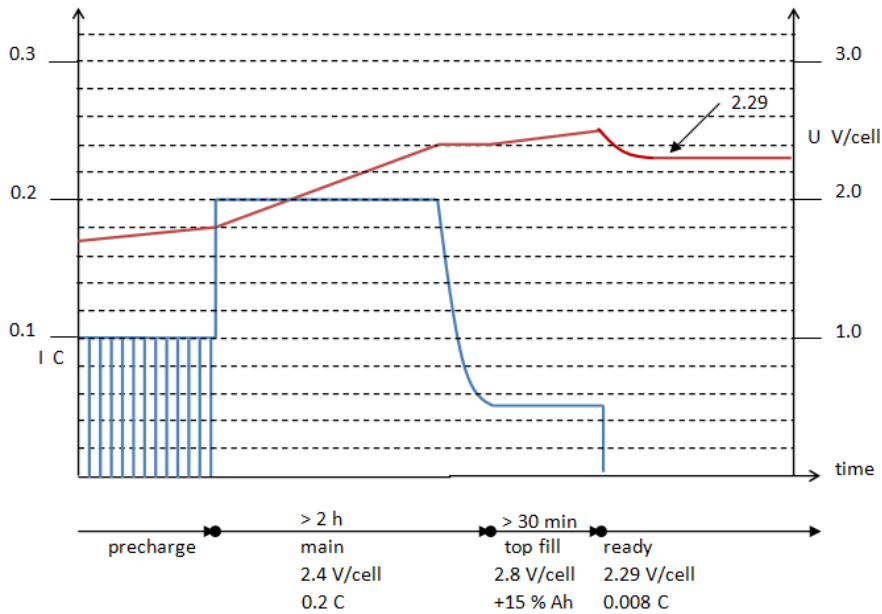

Charging phase "top fill" charges +15 % compared to charged Ah of main phase.

Battery temperature compensation:

- voltage -3 mV / °C per cell, neutral at 30 °C
- current derated to zero in the range [-30 ... -35] and [+45 ... +60] °C

4.5 PP100 freely ventilated lead-acid, with constant voltage maintenance charging

Algorithm number: 17

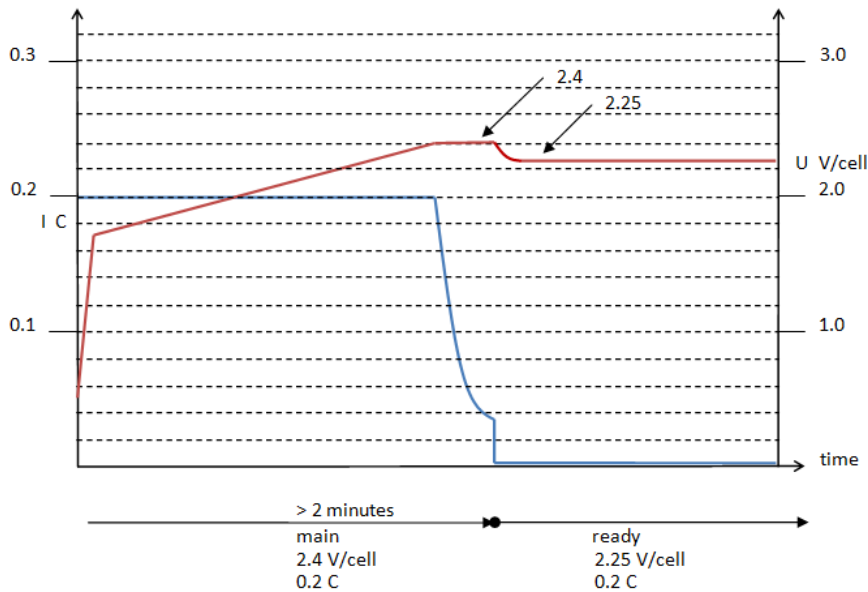

Battery temperature compensation:

- voltage $-4 \text{ mV} / ^\circ\text{C}$ per cell, neutral at $25 \text{ }^\circ\text{C}$
- current derated to zero in the range $[-30 \dots -35]$ and $[+40 \dots +50] \text{ }^\circ\text{C}$

Note, this algorithm uses low battery detection voltage: 0.5 V/cell . Be careful not to inadvertently use battery with smaller number of cells, for example 24 V charger for a 12 V battery.

4.6 PP101 sealed gel lead-acid, with constant voltage maintenance charging

Algorithm number: 18

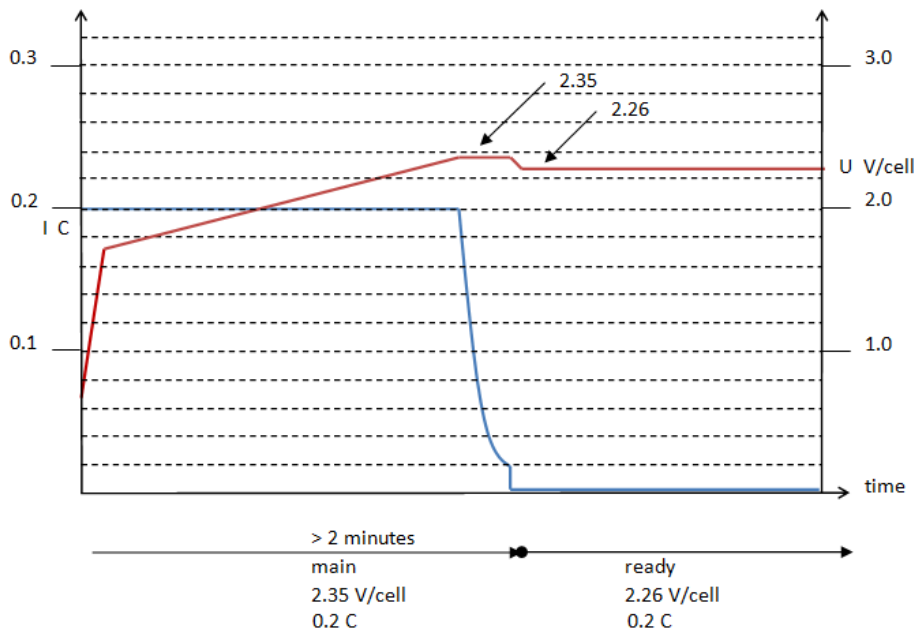

Battery temperature compensation:

- voltage -4 mV / °C per cell, neutral at 25 °C
- current derated to zero in the range [-30 ... -35] and [+40 ... +50] °C

Note, this algorithm uses low battery detection voltage: 0.5 V/cell. Be careful not to inadvertently use battery with smaller number of cells, for example 24 V charger for a 12 V battery.

4.7 PP102 sealed gel lead-acid "Sonnenschein"

Algorithm number: 19

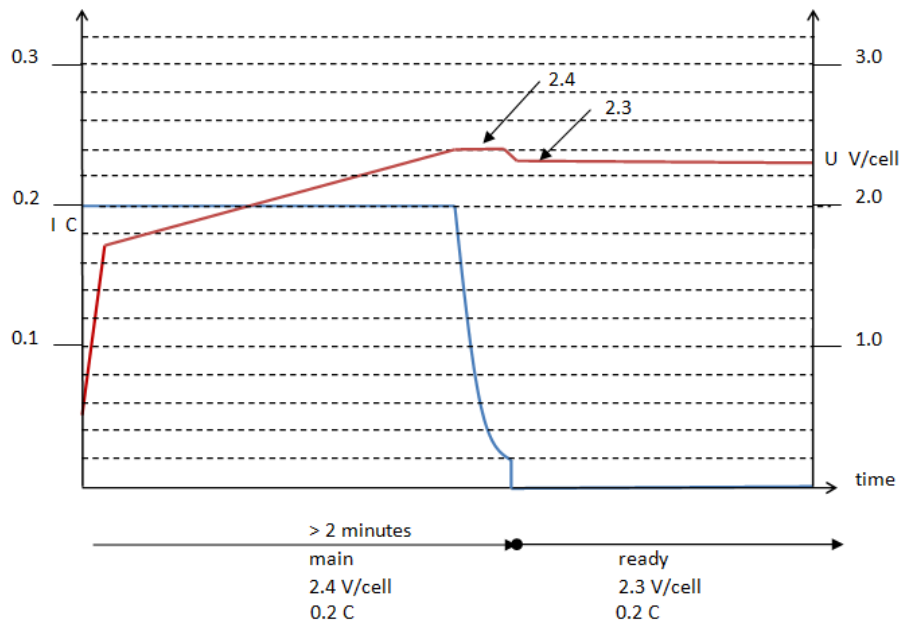

Battery temperature compensation:

- voltage -4 mV / °C per cell, neutral at 25 °C
- current derated to zero in the range [-30 ... -35] and [+40 ... +50] °C

Note, this algorithm uses low battery detection voltage: 0.5 V/cell. Be careful not to inadvertently use battery with smaller number of cells, for example 24 V charger for a 12 V battery.

5 CAN remote control

For physical connection to CAN port, see chapter "Connections".

Robust series CAN communication is not CiA certified nor CANopen complete but communication is based on CANopen. In the following presentation, basic knowledge about CAN and CANopen is assumed.

Frame: Standard CAN frame with 11-bit identifier
 Bit rate: 20 ... 1000 kbit/s
 Node-ID: 1 ... 127

Configurable items are accessed using CANopen SDO protocol. See "Node-ID" for examples of how CAN messages are built.

Nonvolatile settings are nonvolatile without separate save command, automatically written to flash. Therefore, for long lifetime, avoid sending excessive amounts of these messages. Most nonvolatile settings are active immediately but some require restart.

5.1 Node-ID

This CANopen object is used to configure node-ID

index	sub-index	format	unit	range	default value	item
2057h	01	uint8		1...127	1Dh*	CAN node-ID

*Default node-ID is 1 in software version 6 and earlier.

Changed CAN node-ID is nonvolatile, active immediately after response.

Node-ID is automatically assigned in charger mode, so configured node-ID is ignored.

Message to access node-ID is built according to CANopen SDO protocol:

CAN-ID: 600h + node-ID, DLC: 8, data[0]: according to CANopen, data[1-2]: OD index, data[3]: OD subindex, data[4]: node-ID. Unused bytes are ignored.

Example messages

CAN-ID	DLC	data [0..7] (hex)	comment
601h	8	40 57 20 01 00 00 00 00	read CAN node-ID
581h	8	4F 57 20 01 01 00 00 00	response from charger: node-ID is 1

CAN-ID	DLC	data [0..7] (hex)	comment
601h	8	2F 57 20 01 02 00 00 00	write CAN node-ID 2
581h	8	60 57 20 01 01 00 00 00	response from charger

Note, the first data byte in SDO write operation is 2Fh for 1-byte object, 2Bh for 2-byte object and 23h for 4-byte object. For 4-byte object, also 22h can be used. Unused data in response might be filled with random data.

Note, CANopen uses little endian byte order.

5.2 Bit rate

This CANopen object is used to configure bit rate

index	sub-index	format	unit	range	default value	item
5FFFh	02	uint16	kbit/s	20...1000*	125	CAN bit rate

*values 20, 50, 125, 250, 500, 800 and 1000 are supported

Changed bit rate is nonvolatile, active after restart.

This feature is available in software version 7 and later.

5.3 Setting mode via CAN

Mode is defined by two CANopen objects

index	sub-index	format	unit	range	default value	item
2058h	01	uint8		0...3	0	ChargingMode
2056h	01	uint8		0...3	1	CAN function

For a mode, set these two objects to

mode	ChargingMode	CAN function
charger	0	1
PDO power supply	0	3
SDO power supply	2	3
Powerfinn power supply	3	3

Other combinations of values are reserved.

These settings are nonvolatile. Some mode changes are active immediately, some require restart.

This feature is available in software version 7 and later.

5.4 SW version

Charger SW version can be read using SDO objects

index	sub-index	format	unit	range	default value	item
2202h	01	uint32				SW type; 11613002 for standard SW. Does not change for the lifetime of the SW.
2202h	02	uint32				SW version, incremented for new versions.

This feature is available in software version 7 and later.

5.5 Charger mode

At startup, charger sends boot-up message

CAN-ID: 700h + node-ID, DLC: 1, data: 0

Charger sends heartbeat message once per second

CAN-ID: 700h + node-ID, DLC: 1, data: 05h

Charger sends SYNC message once per second

CAN-ID: 080h, DLC: 0

Charger enters operational state automatically. Charger sends some other CAN messages related to automatic group functionality.

Charging parameters

These CANopen SDO objects are used to configure charging parameters.

index	sub-index	format	unit	range	default value	item
2000h	01	uint16			1	algorithm number
2000h	02	uint16	Ah	50...2000	50	battery capacity
2000h	03	uint16		6...50	12*	number of cells
2000h	04	uint16	mA	0...65535	0	base load
2000h	05	uint16	mOhm	0...99	0	cable resistance

* number of cells is set at the factory according to nominal voltage; 12 cells for 24 V model, 18 for 36 V model, 24 for 48 V model.

These settings are nonvolatile.

Measurements or monitoring

In software version 7 and later, measurements are available via Powerfinn power supply mode messages, which work also in charger mode. See chapter "Powerfinn power supply mode"

5.6 PDO power supply mode

This power supply mode uses CANopen PDO protocol.

After startup, charger is in pre-operational state.

Charger sends boot-up message

CAN-ID: 700h + node-ID, DLC: 1, data: 0.

Charger sends heartbeat message once per second

CAN-ID: 700h + node-ID, DLC: 1, data: 7Fh.

Set charger to operational state by sending *start remote node* message

CAN-ID: 000, DLC: 2, data[0]: 1, data[1]: node-ID

for example

CAN-ID	DLC	data (hex)	comment
000h	2	01 01	start device with node-ID 01

Then, charger sends heartbeat message once per second

CAN-ID: 700h + node-ID, DLC: 1, data: 05h.

Note, charger sends some extra messages during startup and change of operational state.

Power output

For power output, three CANopen PDO messages are needed from CAN controller to charger.

1) Voltage and current setting

CAN-ID: 200h + node-ID, DLC: 8, data[0-3]: voltage in Volts, data[4-7]: current in Amperes.

Numeric format: IEEE-754 single precision floating point, 32 bit.

Note the little endian byte order of CANopen. Example message:

CAN-ID	DLC	data (hex)	comment
201h	8	00 00 10 42 00 00 20 42	Uset 36.0 V, Iset 40.0 A

2) Power setting

CAN-ID: 300h + node-ID, DLC: 8, data[0-3]: power in Watts, data[4-7]: not used, set to 0. Numeric format: IEEE-754 single precision floating point, 32 bit.

Example message:

CAN-ID	DLC	data (hex)	comment
301h	8	00 80 89 44 00 00 00 00	Pset 1100 W

3) SYNC

CAN-ID	DLC	data (hex)	comment
080h	1	00	

Period of one second is recommended. If these messages are not received for some seconds, power output is switched off.

Note, configuration item IdLimit applies in PDO power supply mode.

Measurements

In operational state, sending sync produces two PDO messages of measurement data as response.

1) Voltage and current

CAN-ID: 180h + node-ID, DLC: 8, data[0-3]: voltage in Volts, data[4-7] current in Amperes.

Numeric format: IEEE-754 single precision floating point, 32 bit. For example

CAN-ID	DLC	data (hex)	comment
181h	8	B1 88 C3 41 82 01 F0 41	Umeas 24.441733 V, Imeas 30.000736 A

2) Power

CAN-ID: 280h + node-ID, DLC: 8, data[0-3]: power in Watts, data[4-7]: (reserved).

Numeric format: IEEE-754 single precision floating point, 32 bit. For example

CAN-ID	DLC	data (hex)	comment
281h	8	F4 4A 37 44 12 00 00 00	Pmeas 733.17114 W

5.7 SDO power supply mode

In this mode, charger outputs power immediately after startup.

For defining power output, two CANopen SDO objects are used:

index	sub-index	format	unit	range	default value	item
2001h	01	uint32	mV	0...max*	nom**	UdcLimit
2001h	02	uint32	A	0...max*	max*	IdcLimit

* maximum output of the model

** nominal voltage of the model

Note that values are nonvolatile, automatically written to flash. Therefore, for long lifetime, avoid sending excessive amounts of these messages.

Note, configuration item IdcLimit applies also in other operation modes. See "Configurable items" - "IdcLimit".

Example messages

CAN-ID	DLC	data (hex)	comment
601h	8	23 01 20 01 C0 5D 00 00	U set 24000 mV

CAN-ID	DLC	data (hex)	comment
601h	8	23 01 20 02 0A 00 00 00	I set 10 A

At startup, charger CAN behaviour is similar to PDO power supply mode. Entering operational state is not required for power output. It can be entered and measurements are available same way as in PDO power supply mode.

5.8 Powerfinn power supply mode

Powerfinn power supply mode provides close CAN remote control compatibility to Powerfinn PAP3200/CAN product family. This mode is available in software version 7 and later.

Power output

These CANopen SDO objects are used to set power output:

index	sub-index	format	unit	range	default value	item
2401h	01	uint32	mV	0...max*	-**	Uset
2401h	02	uint32	mA	0...max*	-**	Iset

* maximum output of the model

** Default Uset and Default Iset are used as startup values, see below.

These settings are volatile.

After startup, voltage and current settings are initially zero. They can also be set to non-zero values.

index	sub-index	format	unit	range	default value	item
2401h	06	uint32	mV	0...max*	0	Default Uset
2401h	07	uint32	mA	0...max*	0	Default Iset

* maximum output of the model

These settings are nonvolatile.

Measurements

index	sub-index	format	unit	range	default value	item
2402h	01	uint32	mV	0...max	-	Uact, measured output voltage
2402h	02	uint32	mA	0...max	-	Iact, measured output current
2402h	06	int32	0.1 °C	-50...+150 °C	-	internal temperature

CAN safety timer

If a new Uset/Iset message from CAN controller is not found within a time interval (it is assumed that CAN control is lost), active Uset and Iset values are replaced by default Uset and default Iset values. Setting CAN safety timer to zero means this feature is not active.

index	sub-index	format	unit	range	default value	item
2401h	0Bh	uint8	s	0...255	0 (off)	CAN safety timer

This setting is nonvolatile.

Example

After startup, charger sends heartbeat once/second. The data is 7Fh, which hints that device is in pre-operational state. Despite this, there is no need to send *start node* message to output power. Minimum messages to output power in Powerfinn power supply mode are Uset and Iset. Here is a CAN bus log from startup to power output:

#	time s		ID	DLC	data	notes
1	2.208	Tx	071D	1	00	bootup message
2	2.210	Tx	009D	8	00 00 00 00 00 00 00 00	
3	3.207	Tx	071D	1	7F	heartbeat
4	4.207	Tx	071D	1	7F	
5	4.984	Rx	061D	8	22 01 24 01 10 27 00 00	Uset 10 000 mV
6	4.987	Tx	059D	8	60 01 24 01 00 00 00 00	response
7	5.207	Tx	071D	1	7F	
8	6.206	Tx	071D	1	7F	
9	6.596	Rx	061D	8	22 01 24 02 88 13 00 00	Iset 5000 mA
10	6.599	Tx	059D	8	60 01 24 02 00 00 00 00	response
11	7.206	Tx	071D	1	7F	
12	8.205	Tx	071D	1	7F	
13	9.205	Tx	071D	1	7F	

Differences between Robust series Powerfinn power supply mode and PAP3200/CAN power supply mode

SDO download message

First byte "nes" bits (see CiA 301 7.2.4.3.3) need careful setting in Robust series. PAP3200 accepts any alternative for first byte, even a non-correct one. For Robust, they must indicate correct data length, except also 22h as first byte is accepted for four bytes data length.

LED indication

PAP3200/CAN has yellow constantly on. Robust sets big yellow on when power output is on.

High internal temperature

PAP3200/CAN shows red color in its sole LED, Robust shows steady red and blinking yellow. The temperature limits for showing alarm and switching output off, vary somewhat between models. Operating charger within environmental specification ensures internal temperature low enough.

Periodic CAN messages

PAP3200/CAN does not send heartbeat. Robust sends heartbeat CAN-ID:700h + node-ID, DLC:

1, data:7Fh, once per second.

Event related CAN messages

Robust sends some extra messages, for example at startup CAN-ID 800h + node-ID, DLC: 8, data 00 00 00 00 00 00 00 00.

Bootup CAN messages

PAP3200/CAN sends two bootup messages, Robust one. For example

	CAN-ID	DLC	data	CAN-ID	DLC	data
PAP3200	71Dh	1	01	71Dh	1	00
Robust	71Dh	1	00			

The first bootup message from PAP3200/CAN uses fixed node-ID of 1Dh and fixed bit rate 125 kbit/s. The second bootup message uses configured node-ID and bitrate.

CAN safety timer

PAP3200/CAN safety timer can be kept inactive with any message with correct node-ID. Robust requires Uset or lset message.

CAN node-ID

PAP3200/CAN node-ID is accessed using OD index 5FFFh. Robust node-ID can be accessed same way in SW version 7 and later. OD index 2057h works in all Robust SW versions.

Changed node-ID is active after restart in PAP3200/CAN, immediately (after response) in Robust.

5.9 Unidirectional power supply mode

Unidirectional power supply mode replaces PDO power supply mode in SW type 11613011. It allows Powerfinn Robust series chargers to partially emulate some other brands of chargers. The term unidirectional derives from the fact that in this mode CAN controller sends messages to charger but charger does not send messages to CAN controller. Charger does send heartbeat message

CAN-ID: 700h + node-ID, DLC: 1, data: 5, once per second.

Power, voltage and current are set using one message.

CAN-ID: 400h + node-ID, DLC: 8,

data[0]: power on/off, use value 1 for power on, 0 for power off,

data[1-2], power limit in 0.1 % *

data[3-4], voltage in 0.1 Volts,

data[5-6]: current in 0.1 Amperes,

data[7]: (not used)

Numeric format: 16 bit unsigned int.

* Value of 100 % is recommended.

Note the little endian byte order of CANopen. Example message:

CAN-ID	DLC	data (hex)	comment
401h	8	01 E8 03 F4 01 64 00 00	Power on, P=100%, 50.0 V, 10.0 A

Period of one second is recommended. If this message is not received for some seconds, power output is switched off.

6 Connections

Mains cable of Robust 1100 is as standard 1.5 m of length, terminated to european style schuko plug.



Mains cable of Robust 2300 is as standard 2.5 m of length, terminated to european style schuko plug.



DC cables of Robust 1100 chargers are as standard 2*10 mm², 2 m length, not terminated.
DC cables of Robust 2300 chargers are as standard 2*25 mm², 2 m length, not terminated.

Ask your supplier for alternatives.

Robust 1100 chargers provide optional features over 4 pcs of RJ11 sockets located in the bottom side. There are some limitations on connecting these. Not all can be connected at the same time while maintaining IP class. For details, ask your supplier or the manufacturer.

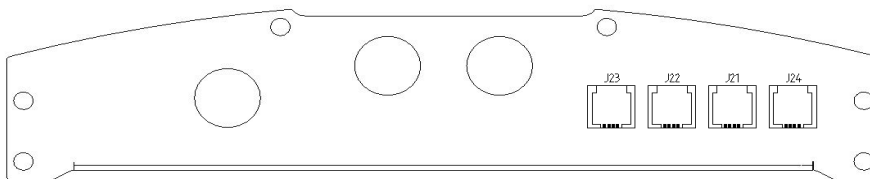

Robust 2300 and 3000 chargers provide optional features over a 26-pin high-density D-sub socket located in the bottom side.

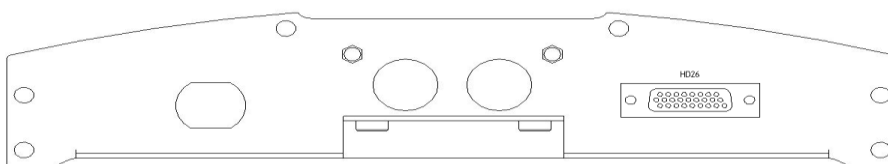

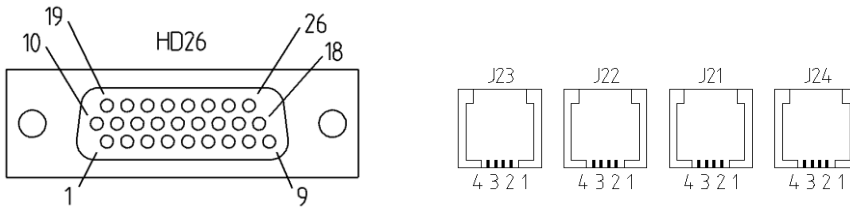

RJ pin	RJ wire color	HD26 pin	Description
J23-1	black	4	LED green anode (10mA current source)
J23-2	red	22	LED common cathode (connected to battery minus)
J23-3	green	14	LED red anode (10mA current source)
J23-4	yellow	5	LED yellow anode (10mA current source)
J22-1	black	2	Sense plus (+)
J22-2	red	12	Battery temperature compensation (-) (Sensor consists of two Philips KTY83-120 sensors connected in series)
J22-3	green	3	Battery temperature compensation (+)
J22-4	yellow	20	Sense minus (-)
J21-1	black	19	Remote input (+) *
J21-2	red	1	CAN-bus Hi *
J21-3	green	10	CAN-bus Lo *
J21-4	yellow	11	Remote input (-) *
J24-1	black	26	Remote output relay, Common (0.5A@125Vac, 2A@30VDC, 0.3A@110VDC)
J24-2	red	18	Remote output relay, Normally Open
J24-3	green	9	Remote output relay, Normally Closed
J24-4	yellow		Not connected
		25	Isolated +5V, 50 mA output *
		7	Isolated output ground * (same ground as in HD26 pin 11)

* Note: CAN bus signals, remote input and isolated 5 V output operate from supply, which is galvanically isolated from charger DC output.

CAN bus is using internally weak split termination (2 * 1 kOhm, 100 nF).

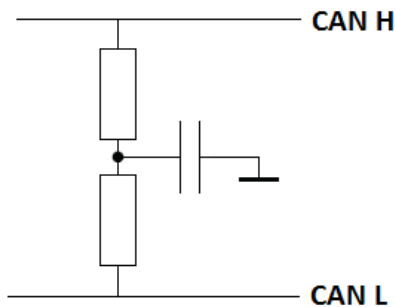

For available cables to utilize these optional features, see chapter "Options and accessories".

7 Options and accessories

Options and accessories in addition to those listed here might be available. Ask your supplier.

7.1 Radio module

Robust series chargers can be equipped at the factory with optional internal radio module. Radio module enables short range communication with other chargers and battery monitoring units. Also communication to PC-computer via USB radio dongle is possible. The radio functionality of Powerfinn Robust series and Micropower Access series is compatible.

Microsoft Windows™ software "MP Access Service Tool" is convenient tool for

- configuring chargers and the system
- reading logs and statistical data from charger
- monitoring charger operation in real time

For more information on using the radio functionality, see MP Access documentation.

7.2 Option cable with all wires connected

Molded package with integrated 2 m cable, IP67, wires appr. AWG26 / 0.13 mm², unterminated

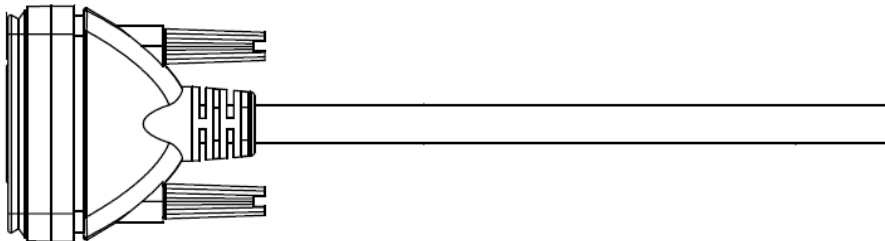

pin numbers and wire colors

01 brown	14 brown/white
02 blue	15 red/white
03 white	16 orange/white
04 green	17 green/white
05 yellow	18 blue/white
06 gray	19 purple/white
07 pink	20 red/black
08 red	21 orange/black
09 black	22 yellow/black
10 orange	23 green/black
11 purple	24 gray/black
12 light green	25 pink/black
13 black/white	26 pink/red

7.3 Battery temperature sensor and voltage sense

In charger mode, battery temperature compensation is automatically used, if sensor is connected and selected algorithm has temperature compensation defined.

In charger mode, DC cable voltage loss compensation can be done programmatically using charging parameter "cable resistance". Compensation can also be done by hardware using sense wires. This method works in all modes.



Length 2.5m to first joint, total 3.2 m, IP67 at charger end, IPxx at fuse holder, other joints molded. The black rectangular piece is temperature sensor and is attached externally to the battery pack. Black and red ring terminals are connected to - and + poles. Positive wire also has a fuse (3 A, type ATO).

For Robust models with RJ11 connectors, similar accessory is available.

7.4 CAN cable

CAN cable for Robust 2300 and 3000 charger is as standard 2 m in length, IP67, not terminated. Not terminated both in terms of second connector and line impedance.

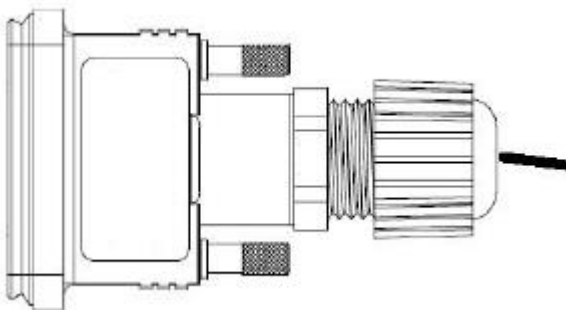

HD26M pin	wire color	signal
10	white	CAN_L
1	brown	CAN_H

For Robust models with RJ11 connectors, similar accessory is available.

8 Dimensions

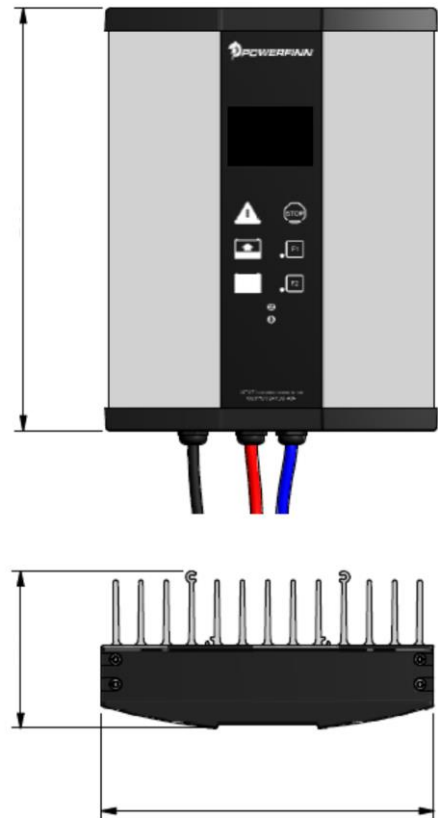

Approximate dimensions in mm.

Height excluding cable clamps.

Weight including standard cables, excluding accessories and package.

model	height	width	depth	weight kg
Robust 1100 passive	290	230	110	5.8
Robust 1100 fan	330	230	80	3.9
Robust 2300 passive	330	230	110	8.5
Robust 2300 fan	370	230	80	6.1
Robust 3000 fan	370	230	80	